

NOTE :

1. Material : Brass
2. Plate : Sn over nickel
3. The surface should be clean
4. Dimension : 0.5(H)-5.0(Ø)-M3

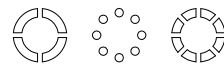
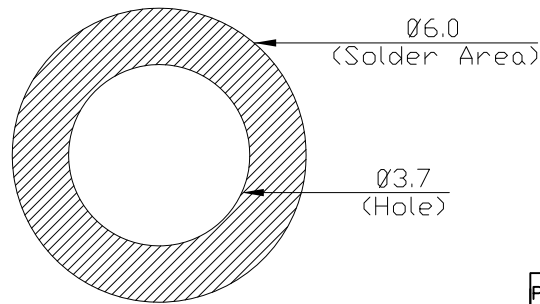
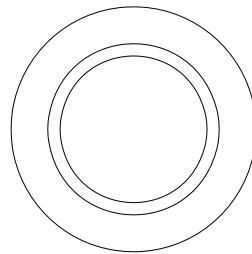
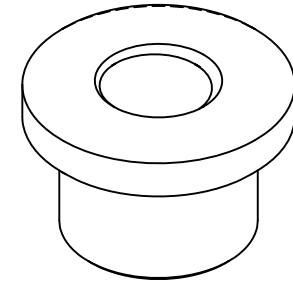
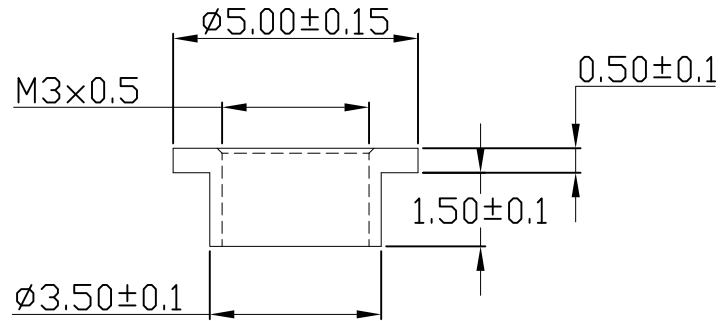

Stencil Masking Examples

PROPRIETARY NOTE:

This document contains confidential information and proprietary to Rego Electronics and shall not be reproduced or disclosed to other documents or used for any purpose other than that for which was obtained without the expressed written consent of Rego Electronics.

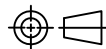
| | | |
|---|-----------------|--|
| .X ± 0.30 | APPROVED: Chris |  http://www.rego.com.tw |
| .XX ± 0.20 | CHECKED: Andy | |
| .XXX ± 0.15 | DRAWN: Vic | TITLE: Stand Off Ø5.00 x 2.00mm (H:0.5) |
| X° ± 3' | UNITS: mm | PART NO: SO-M30H05D500 |
|  | SCALE: NONE | SHEET: 1 OF 2 |

| | |
|-----|------------|
| A | 05.11.2019 |
| REV | DATE |

1 2 3 4 5 6 7 8 9 10

A

B

C

D

E

F

1. 10 sprocket hole pitch cumulative tolerance $\pm 0.20\text{mm}$.
2. Carrier camber not to exceed 1mm in 250mm.
3. A_0 and B_0 measured on a plane 0.3mm above the bottom of the pocket.
4. K_0 measured from a plane on the inside bottom of the pocket to the top surface of the carrier.
5. All dimensions meet EIA-481-B requirements.
6. Material: Black Conductive Polystyrene.
7. Packing length per 22" reel : 82 Meters.(1:3)
8. Component load per 13" reel : 3300 pcs.

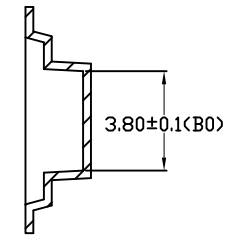
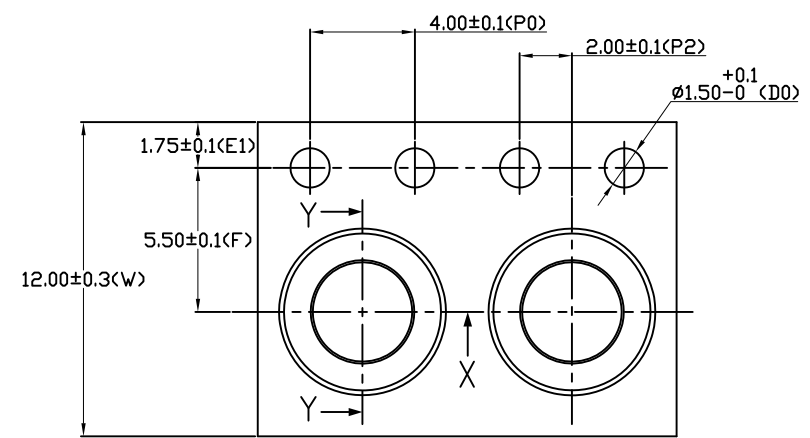

SECTION Y-Y

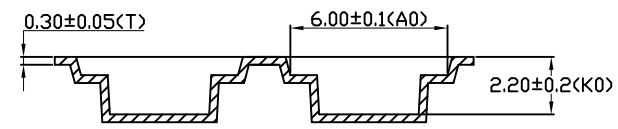

SECTION X-X

| | |
|-----|------------|
| A | 05.11.2019 |
| REV | DATE |

| | | |
|---|-----------------|---|
| PROPRIETARY NOTE: This document contains confidential information and proprietary to Rego Electronics and shall not be reproduced or disclosed to other documents or used for any purpose other than that for which was obtained without the expressed written consent of Rego Electronics. | | |
| .X ± 0.30 | APPROVED: Chris |  TITLE: Stand Off $\varnothing 5.00 \times 2.00\text{mm}$ (H:0.5) |
| .XX ± 0.20 | CHECKED: Andy | |
| .XXX ± 0.15 | DRAWN: Vic | |
| $X^\circ \pm 3^\circ$ | UNITS: mm | SCALE: NONE |
| PART NO: SO-M30H05D500 SHEET: 2 OF 2 | | |

1 2 3 4 5 6 7 8 9 10