

1 2 3 4 5 6 7 8 9 10

A

B

C

D

E

F

A

B

C

D

E

F

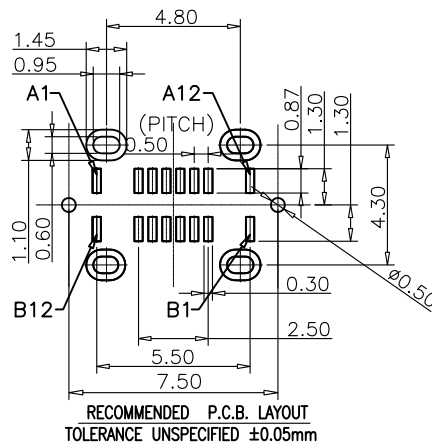
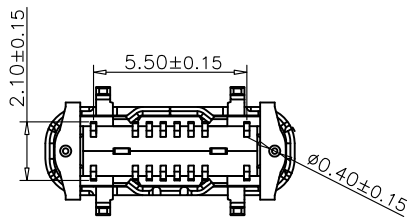
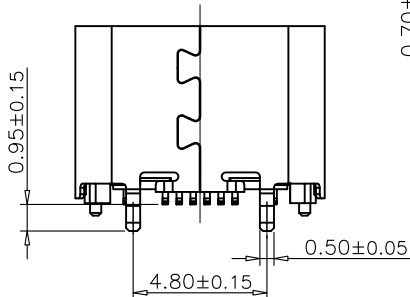
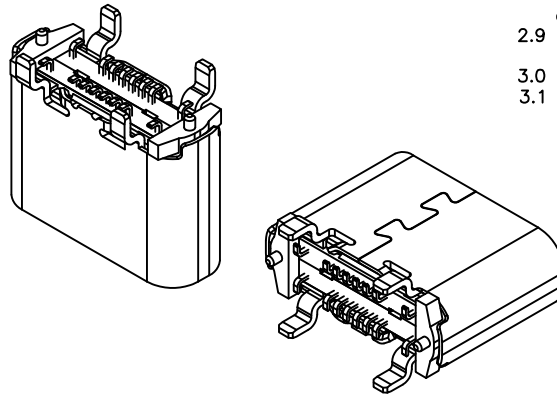
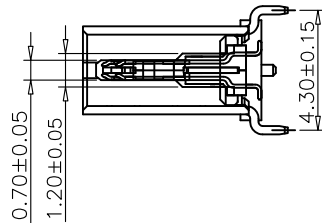
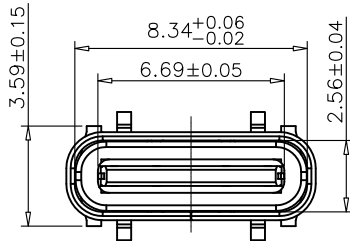
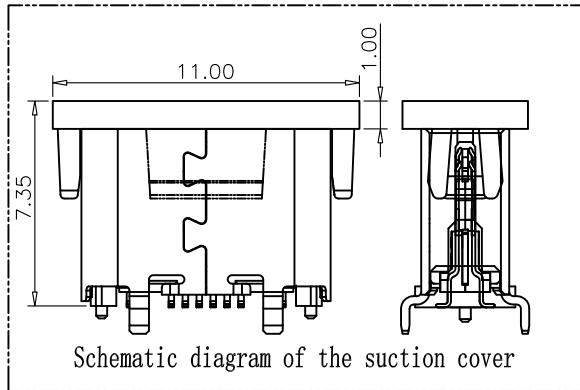
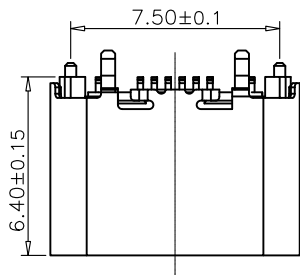

NOTE:

- 1. Material:
- 1.1 Plastic core: LCP+30%G.F UL94V-0
- 1.2 Terminal: High Conductivity Copper Nickel Bottom 50U" MIN.
Contact area gold plated (AU 1u")
Gold plating on the soldering area G/F
- 1.3 Enclosure: SUS304. Nickel-plated surface 50U" MIN
- 1.4 Middle clip: SUS304.
- 2. Main features:
- 2.1 Rated current: 5A
- 2.2 Contact impedance: 40mΩ MAX (Initial value)
50mΩ MAX (After test)
- 2.3 Insulation impedance: 100MΩ MIN
- 2.4 Withstand voltage test: 100V AC R.M.S.
- 2.6 overall insertion force: 5-20N
overall insertion force: 5-20N (After durability)
Overall pull-out force: 8-20N
Overall pull-out force: 6-20N (After durability)
- 2.7 Durable: 10000 times
- 2.8 High temperature resistance: SMT Reflow (peak value 260±5°).
The plastic should not have defects such as foaming, melting glue, etc., Discoloration, warpage within tolerance;
- 2.9 Products subject to solder testing, The sticky tin surface can reach more than 95%;
- 3.0 Salt spray test: 48H MIN
- 3.1 Operating temperature: -30°C ~ +85°C

A1	GND	B12	GND
A4	VBUS	B9	VBUS
A5	CC1	B8	SBU2
A6	DP1	B7	DN2
A7	DN1	B6	DP2
A8	SBU1	B5	CC2
A9	VBUS	B4	VBUS
A12	GND	B1	GND
PIN	SIGNAL NAME	PIN	SIGNAL NAME

PROPRIETARY NOTE:

This document contains confidential information and proprietary to Rego Electronics and shall not be reproduced or disclosed to other documents or used for any purpose other than that for which was obtained without the expressed written consent of Rego Electronics.

.X ± 0.30	APPROVED:	 http://www.rego.com.tw
.XX ± 0.20	Chris	
.XXX ± 0.15	CHECKED: Andy	
X* ± 3'	DRAWN: Vic	
UNITS: mm	SCALE: NONE	TITLE: USB Type C 16 Pins Vertical SMT+DIP Type H:6.5mm
		PART NO: 9177USB31-F00057
		SHEET: 1 OF 1

A	11.5.2022
REV	DATE

1 2 3 4 5 6 7 8 9 10