

1 2 3 4 5 6 7 8 9 10

A
B
C
D
E
F

NOTES:
 1.MATERIAL:
 HOUSING: LCP, UL94V-0, Black
 CONTACT: PHOSPHOR BRONZE(C5191R-H)
 HOLDDOWN: BRASS (C2680R-H)
 2.FINISH:
 CONTACT:
 CONTACT AREA: G/F GOLD PLATED
 SOLDER AREA: MATTE TIN PLATED
 UNDER PLATING: 50u" NICKEL PLATED.
 HOLDDOWN:
 SOLDER AREA: MATTE TIN PLATED
 UNDER PLATING: 50u" NICKEL PLATED.
 3.SPECIFICATION:
 CURRENT RATING: 0.3A / (1PIN)
 VOLTAGE RATING: 25V AC
 DIELECTRIC WITHSTANDING: 250V AC FOR 1 MINUTE
 CONTACT RESISTANCE: 30mΩ Max.
 INSULATION RESISTANCE: 500MΩ Min
 OPERATING TEMPERATURE: -40°C to +90°C
 DURABILITY: 50 CYCLES MIN.
 INSERTION FORCE: 20N MAX.
 WITHDRAWAL FORCE: 25N

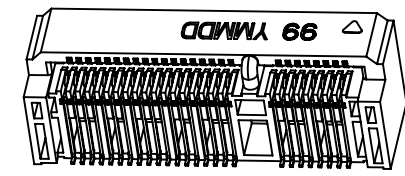
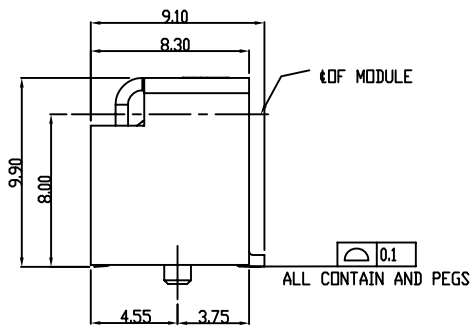
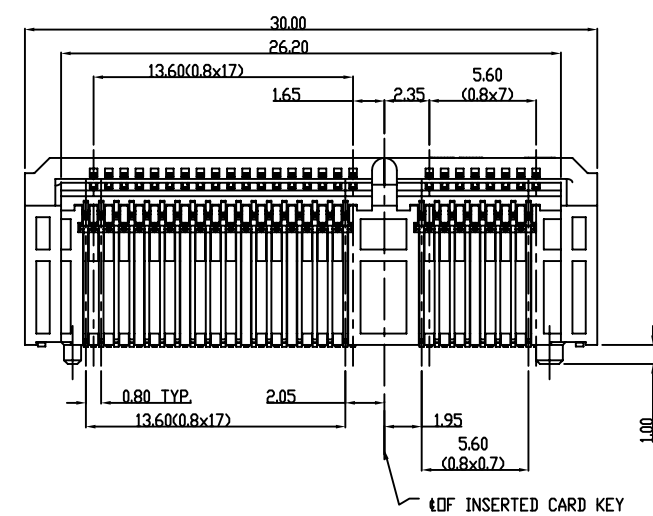
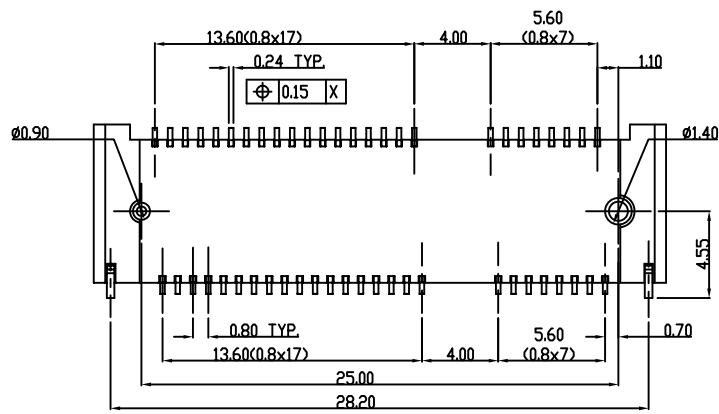
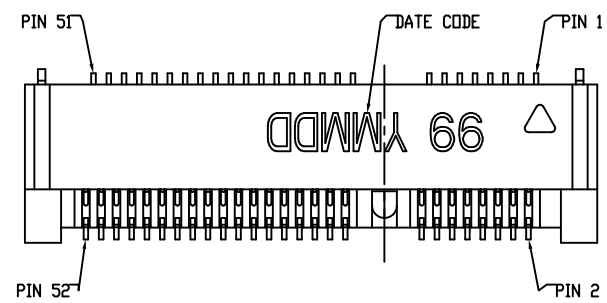

PRODUCT NO.	ITEM	PART NAME	QTY	MATERIAL	PLATING
906MPCIE-0299*X'	1	BODY	1	LCP	
	2	CONTACT	52	PHOSPHOR BRONZE	SELECTED GOLD
	3	HOLD DOWN	2	BRASS	TIN 100u"

PART NO:
906MPCIE-0299*X'

PLATING:
 0 : GOLD G/F
 3 : GOLD 10u"
 5 : GOLD 30u"

PROPRIETARY NOTE:
 This document contains confidential information and proprietary to Rego Electronics and shall not be reproduced or disclosed to other documents or used for any purpose other than that for which was obtained without the expressed written consent of Rego Electronics.

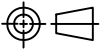
.X ± 0.30	APPROVED:	 http://www.rego.com.tw
.XX ± 0.20	CHECKED:	
.XXX ± 0.15	DRAWN:	
X* ± 3'	UNITS:	TITLE: MINI PCI EXPRESS CONNECTOR 9.9H
	mm	PART NO: 906MPCIE-02990
	SCALE: NONE	SHEET: 1 OF 3

A2	12.11.2021
REV	DATE

1 2 3 4 5 6 7 8 9 10

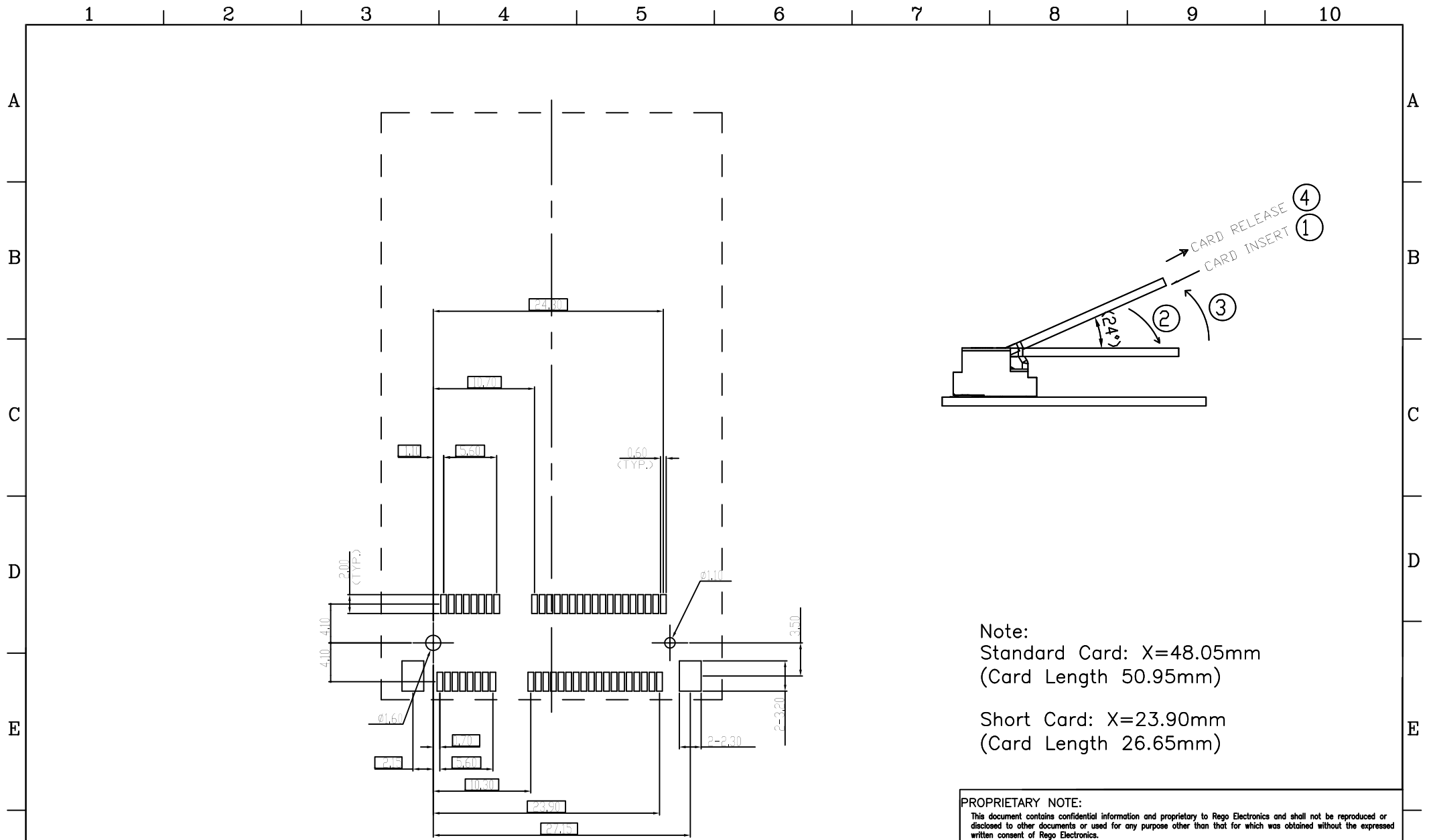

RECOMMEND PC BOARD LAYOUT
GENERAL TOLERANCE: $\pm 0.05\text{mm}$

Note:
Standard Card: X=48.05mm
(Card Length 50.95mm)

Short Card: X=23.90mm
(Card Length 26.65mm)

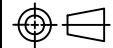

PROPRIETARY NOTE: This document contains confidential information and proprietary to Rego Electronics and shall not be reproduced or disclosed to other documents or used for any purpose other than that for which was obtained without the expressed written consent of Rego Electronics.			
.X ± 0.30	APPROVED:	Chris	 http://www.rego.com.tw
.XX ± 0.20	CHECKED:	Andy	
.XXX ± 0.15	DRAWN:	Vic	
X* $\pm 3'$			
	UNITS:	SCALE:	TITLE: MINI PCI EXPRESS CONNECTOR 9.9H
	mm	NONE	PART NO: 906MPCIE-02990
			SHEET: 2 OF 3

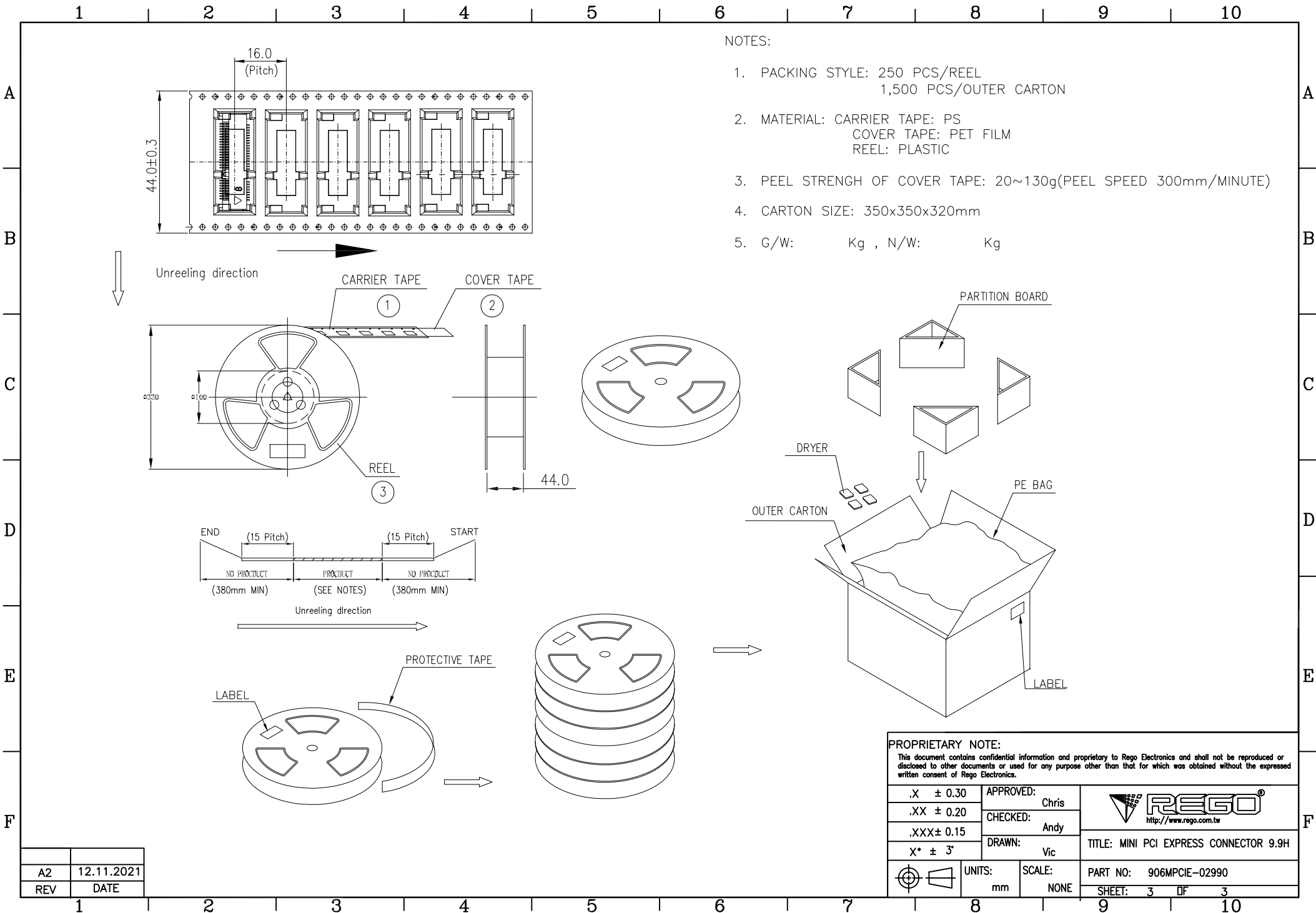
A2	12.11.2021
REV	DATE



NOTES:

1. PACKING STYLE: 250 PCS/REEL
1,500 PCS/OUTER CARTON
2. MATERIAL: CARRIER TAPE: PS
COVER TAPE: PET FILM
REEL: PLASTIC
3. PEEL STRENGTH OF COVER TAPE: 20~130g(PEEL SPEED 300mm/MINUTE)
4. CARTON SIZE: 350x350x320mm
5. G/W: Kg , N/W: Kg

PROPRIETARY NOTE: This document contains confidential information and proprietary to Rego Electronics and shall not be reproduced or disclosed to other documents or used for any purpose other than that for which was obtained without the expressed written consent of Rego Electronics.		
.X ± 0.30	APPROVED: Chris	 http://www.rego.com.tw
.XX ± 0.20	CHECKED: Andy	
.XXX ± 0.15	DRAWN: Vic	
X* ± 3'		
 UNITS: mm	SCALE: NONE	TITLE: MINI PCI EXPRESS CONNECTOR 9.9H
		PART NO: 906MPCIE-02990
		SHEET: 3 OF 3

A2	12.11.2021
REV	DATE