

1 2 3 4 5 6 7 8 9 10

A

B

C

D

E

F

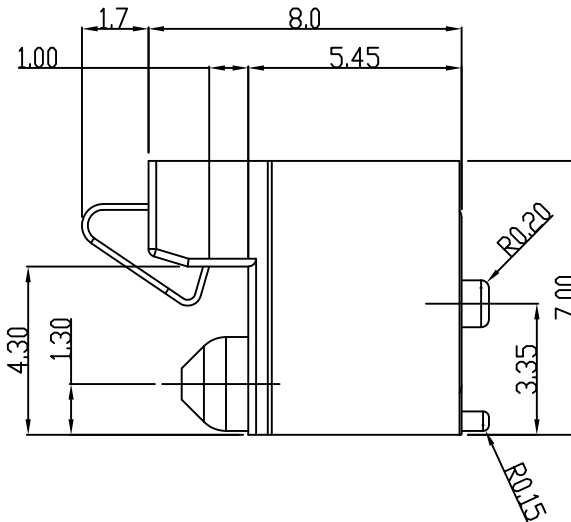
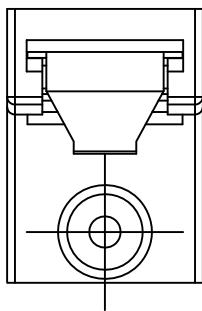

PACK & PLASE AREA  $\phi 3.2$

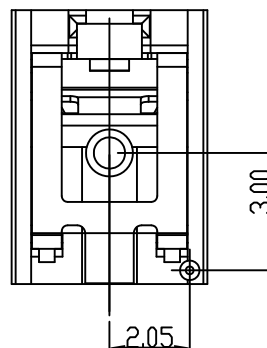
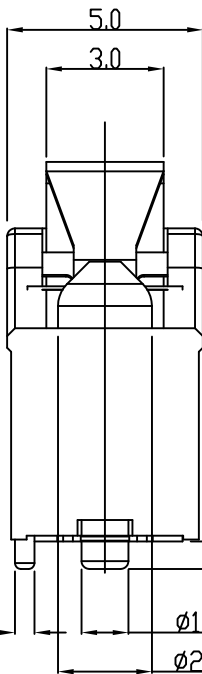
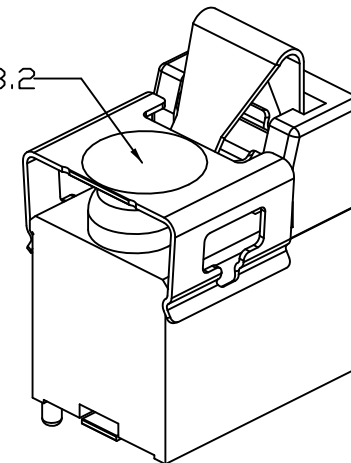

NOTES:

1.MATERIAL:

HOUSING: LCP, UL94V-0, Black  
 LATCH: PHOSPHOR BRONZE  
 COVER: SUS304

2.FINISH:

LATCH:

SOLDER AREA: 100u" TIN PLATED  
 UNDER PLATING: 50u" NICKEL PLATED.

3.SPECIFICATION:

OPERATING TEMPERATURE: -40°C to +90°C

PROPRIETARY NOTE:

This document contains confidential information and proprietary to Rego Electronics and shall not be reproduced or disclosed to other documents or used for any purpose other than that for which was obtained without the expressed written consent of Rego Electronics.

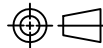
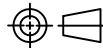
.X ± 0.30	APPROVED: Chris	 <a href="http://www.rego.com.tw">http://www.rego.com.tw</a>
.XX ± 0.20	CHECKED: Andy	
.XXX ± 0.15	DRAWN: Vic	
X* ± 3'	UNITS: mm	SCALE: NONE
		TITLE: Mini PCI Express Latch H:8.0mm
		PART NO: 906MPE-Latch-04
		SHEET: 1 OF 3

AO	28.9.2018
REV	DATE

1 2 3 4 5 6 7 8 9 10

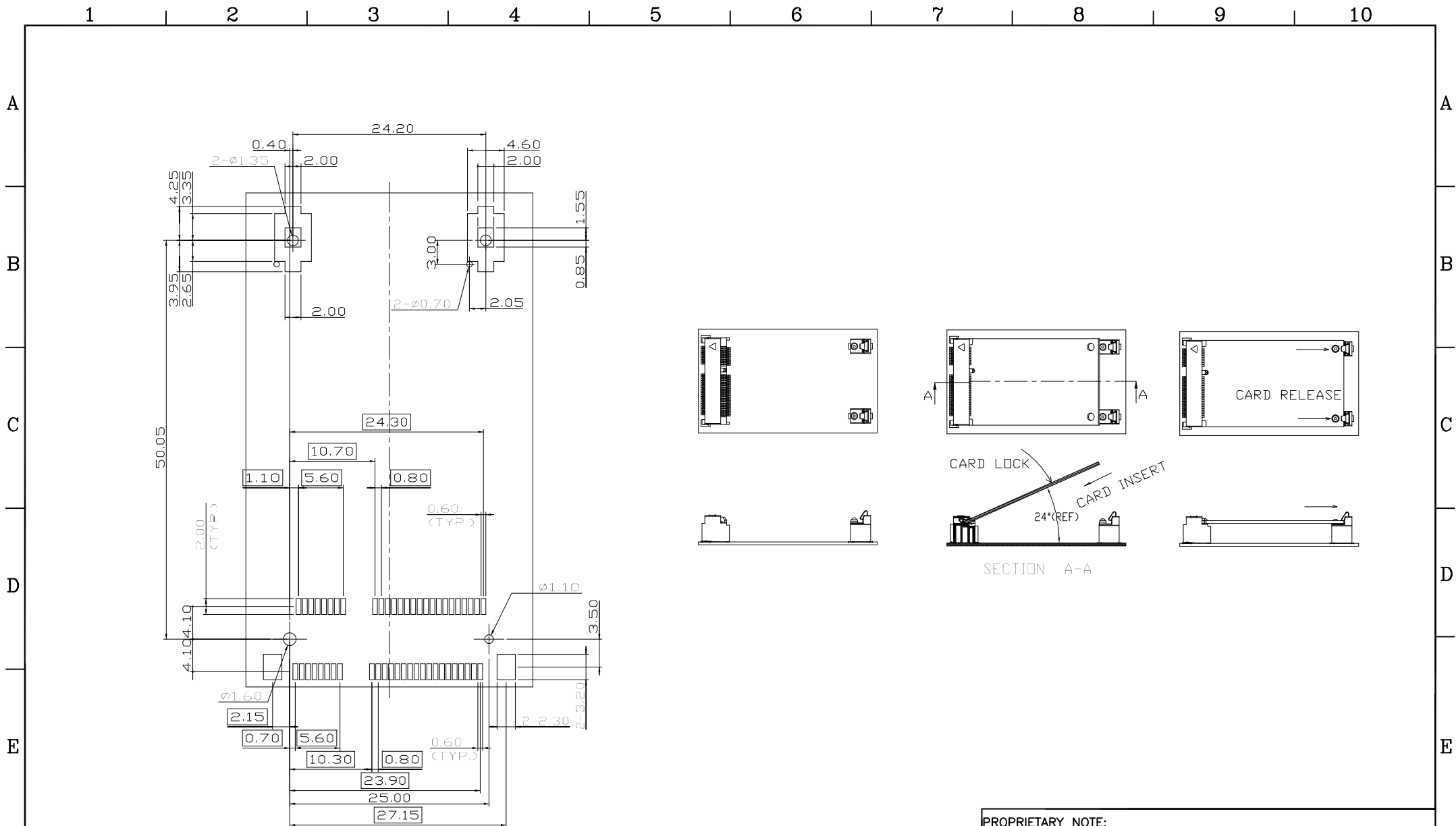

RECOMMEND PC BOARD LAYOUT  
 GENERAL TOLERANCE: ±0.05mm

**PROPRIETARY NOTE:**  
 This document contains confidential information and proprietary to Rego Electronics and shall not be reproduced or disclosed to other documents or used for any purpose other than that for which was obtained without the expressed written consent of Rego Electronics.

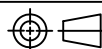
.X ± 0.30	APPROVED: Chris	 <a href="http://www.rego.com.tw">http://www.rego.com.tw</a>
.XX ± 0.20	CHECKED: Andy	
.XXX ± 0.15	DRAWN: Vic	TITLE: Mini PCI Express Latch H:8.0mm
X° ± 3'	UNITS: mm	SCALE: NONE
		PART NO: 906MPE-Latch-04
		SHEET: 2 OF 3

A0	28.9.2018
REV	DATE

1 2 3 4 5 6 7 8 9 10

A

B

C

D

E

F

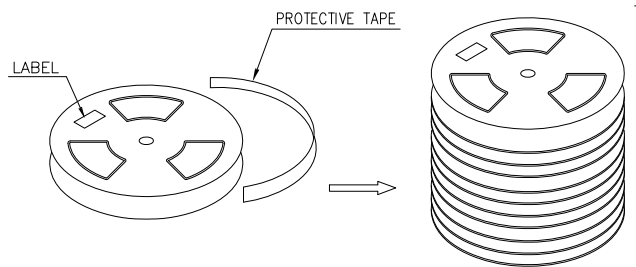
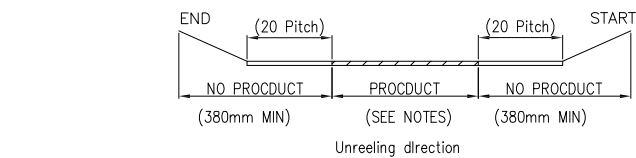
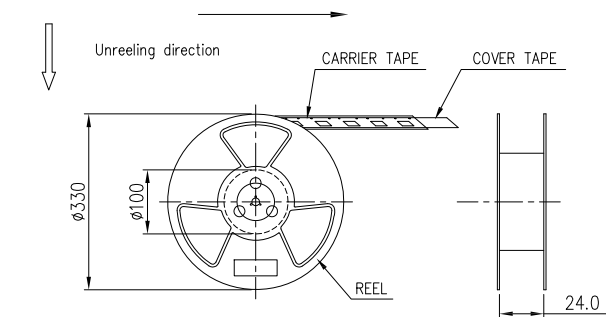
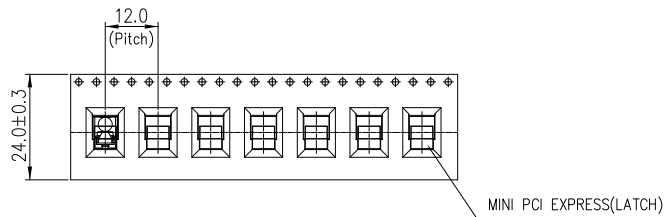

NOTES:

1. PACKING STYLE

906MPE-Latch-01	4.0H	700 PCS/REEL 7,000 PCS/OUTER CARTON
906MPE-Latch-02	5.2H	600 PCS/REEL 6,000 PCS/OUTER CARTON
906MPE-Latch-03	5.6H	550 PCS/REEL 5,500 PCS/OUTER CARTON
906MPE-Latch-04	8.0H	400 PCS/REEL 4,000 PCS/OUTER CARTON
906MPE-Latch-05	9.2H	300 PCS/REEL 3,000 PCS/OUTER CARTON

2. MATERIAL: CARRIER TAPE: PS BLACK

COVER TAPE: PET FILM

REEL: PLASTIC

3. PEEL STRENGTH OF COVER TAPE: 20~80g(PEEL SPEED 300mm/MINUTE)

4. CARTON SIZE: 360x360x330mm

5. G/W: Kg , N/W: Kg

PROPRIETARY NOTE:

This document contains confidential information and proprietary to Rego Electronics and shall not be reproduced or disclosed to other documents or used for any purpose other than that for which was obtained without the expressed written consent of Rego Electronics.

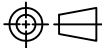
.X ± 0.30	APPROVED: Chris	 <a href="http://www.rego.com.tw">http://www.rego.com.tw</a>
.XX ± 0.20	CHECKED: Andy	
.XXX ± 0.15	DRAWN: Vic	TITLE: Mini PCI Express Latch H:8.0mm
X* ± 3'		
	UNITS: mm	SCALE: NONE
		PART NO: 906MPE-Latch-04
		SHEET: 3 OF 3

AO	28.9.2018
REV	DATE

1 2 3 4 5 6 7 8 9 10