

1 2 3 4 5 6 7 8 9 10

A

B

C

D

E

F

SPECIFICATIONS:

1. ELECTRICAL CHARACTERISTICS
 - 1-1. CURRENT RATING: 0.5 AMP
 - 1-2. VOLTAGE RATING: 40 V
 - 1-3. CONTACT RESISTANCE: 30MILLIOHMS MAX
 - 1-4. INSULATION RESISTANCE: 100M MIN. @500V DC
 - 1-5. DIELECTRIC WITHSTANDING VOLTAGE: 500V AC FOR 1 MINUTE
2. MECHANICAL CHARACTERISTICS:
 - 2-1. INSERTION FORCE : 4.5KGF MAX.
 - 2-2. WITHDRAWING FORCE : 1KGF ~ 4KGF.
3. LIFE TEST: 10000 CYCLES
4. OPERATING TEMPERATURE: -25°C TO +85°C

| | | | |
|----|-----------|-----|---|
| C | SHELL | 1 | C2680R-H Ni 50u" T=0.4mm PLATING ALL OVER |
| B | TERMINAL | 19 | C2680R-H, T=0.2±0.02mm |
| A | HOUSING | 1 | LCP E130I UL94V-O BLACK |
| NO | PART NAME | QTY | MATERIAL PLATING & COLOR |

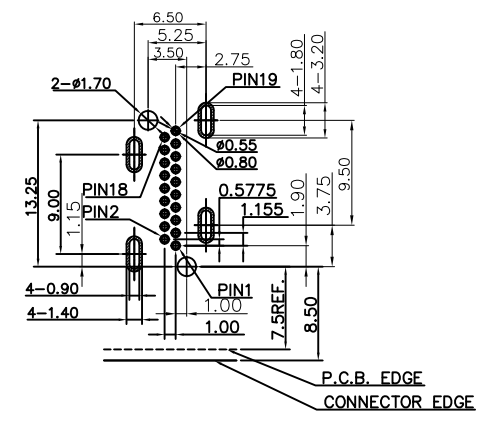
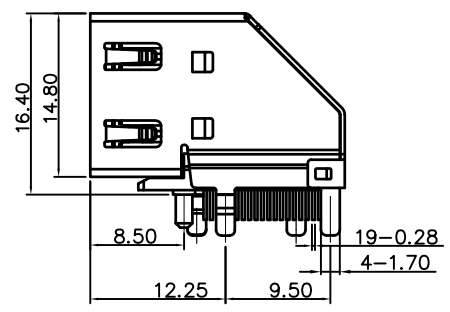
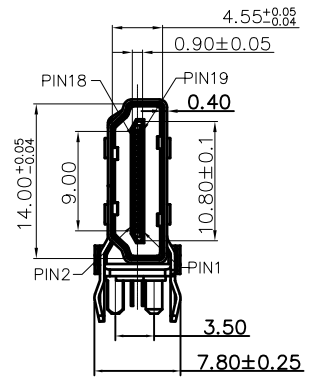
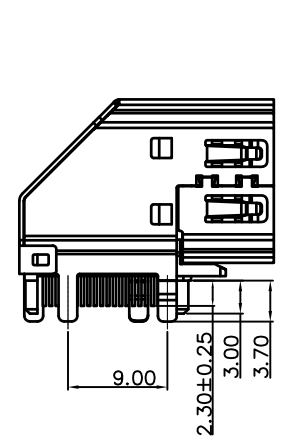
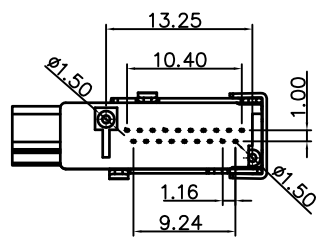
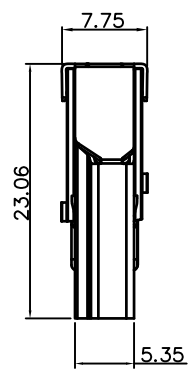

RECOMMENDED PCB LAYOUT (TOP VIEW)
TOLERANCE: ±0.05mm

| | |
|-----|-----------|
| 0 | 21.1.2021 |
| REV | DATE |

1 2 3 4 5 6 7 8 9 10

PROPRIETARY NOTE:

This document contains confidential information and proprietary to Rego Electronics and shall not be reproduced or disclosed to other documents or used for any purpose other than that for which was obtained without the expressed written consent of Rego Electronics.

| | | |
|-------------|-----------|--|
| .X ± 0.30 | APPROVED: |  http://www.rego.com.tw |
| .XX ± 0.20 | Chris | |
| .XXX ± 0.15 | CHECKED: | |
| X° ± 3° | Andy | |
| | DRAWN: | TITLE: HDMI 2.1 Female Connector , Upright DIP Type H: 16.4mm |
| | Vic | |
| | UNITS: | PART NO: RG9916-117B30-01B0 SHEET: 1 OF 1 |
| | mm | |
| | SCALE: | NONE |