

1 2 3 4 5 6 7 8 9 10

A
B
C
D
E
F

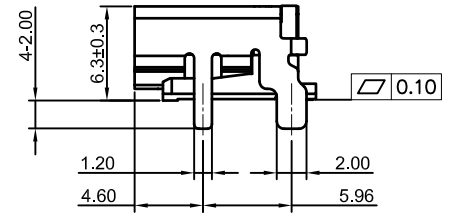
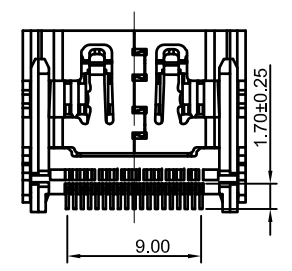
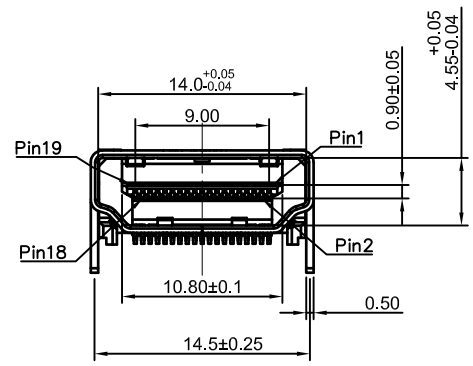
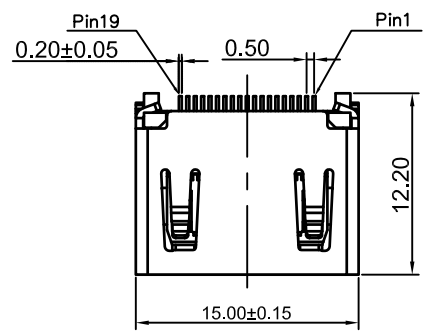

SPECIFICATIONS:
1. ELECTRICAL CHARACTERISTICS
 1-1. CURRENT RATING: 0.5 AMP
 1-2. VOLTAGE RATING: 40 V
 1-3. CONTACT RESISTANCE: 30MILLIOHMS MAX
 1-4. INSULATION RESISTANCE: 100M MIN. @ 500V DC
 1-5. DIELECTRIC WITHSTANDING VOLTAGE: 500V AC FOR 1 MINUTE
2. MECHANICAL CHARACTERISTICS:
 2-1. INSERTION FORCE : 4.5KGF MAX.
 2-2. WITHDRAWING FORCE : 1KGF ~ 4KGF.
3. LIFE TEST: 10000 CYCLES
4. OPERATING TEMPERATURE: -25°C TO +85°C

C	SHELL	1	C2680R-H Ni 50u" T=0.5mm PLATING ALL OVER
B	TERMINAL	19	C2680R-H SEE PART NO.
A	HOUSING	1	LCP E130i UL94V-0 BLACK
NO	PART NAME	QTY	MATERIAL PLATING & COLOR

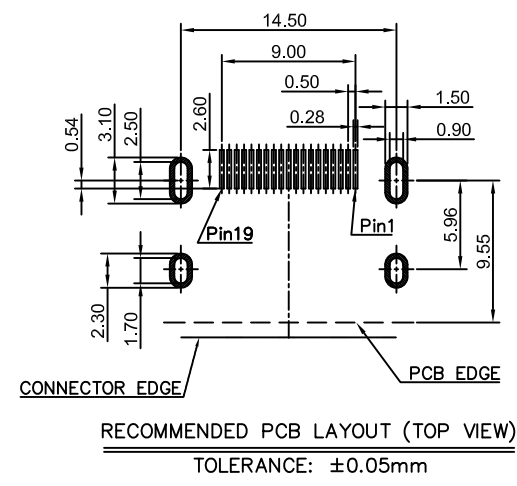

0	22.1.2021
REV	DATE

PROPRIETARY NOTE:
 This document contains confidential information and proprietary to Rego Electronics and shall not be reproduced or disclosed to other documents or used for any purpose other than that for which was obtained without the expressed written consent of Rego Electronics.

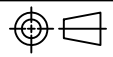
.X ± 0.30	APPROVED: Chris	 http://www.rego.com.tw	
.XX ± 0.20	CHECKED: Andy		
.XXX ± 0.15	DRAWN: Vic		
X° ± 3°		TITLE: HDMI 2.1 Female Connector , Right Angle SMT Type H: 6.3mm	
	UNITS: mm	SCALE: NONE	PART NO: RG9918-117A10-02B0
			SHEET: 1 OF 1

1 2 3 4 5 6 7 8 9 10