

NOTES:



1.MATERIAL:
 HOUSING: LCP, UL94V-0, Black
 CONTACT: PHOSPHOR BRONZE(C5210R-EH)
 HOLDDOWN: BRASS(C2680R-H)

2.FINISH:
 CONTACT:
 CONTACT AREA: G/F GOLD PLATED
 SOLDER AREA: G/F GOLD PLATED
 UNDER PLATING: NICKEL PLATED.
 HOLDDOWN:
 SOLDER AREA: 100u" TIN PLATED
 UNDER PLATING: NICKEL PLATED.

3.SPECIFICATION:
 CURRENT RATING: 0.5A / (1PIN)
 VOLTAGE RATING: 50V AC
 DIELECTRIC WITHSTANDING: 300V AC FOR 1 MINUTE
 CONTACT RESISTANCE: 55mΩ Max.
 INSULATION RESISTANCE: 500MΩ Min
 OPERATING TEMPERATURE: -40°C to +85°C
 DURABILITY: 60 CYCLES MIN.
 INSERTION FORCE: 20N MAX.
 WITHDRAWAL FORCE: 25N

SECTION A-A

MATING CONDITION SCALE: 2:1

| | | | |
|---|-----------|--------|--|
| PROPRIETARY NOTE: This document contains confidential information and proprietary to Rego Electronics and shall not be reproduced or disclosed to other documents or used for any purpose other than that for which was obtained without the expressed written consent of Rego Electronics. | | | |
| .X ± 0.30 | APPROVED: | Chris |  http://www.rego.com.tw |
| .XX ± 0.20 | CHECKED: | Andy | |
| .XXX ± 0.15 | DRAWN: | Vic | |
| X* ± 3' | | | TITLE: M.2 Connector 2.15H A Key Type |
|  | UNITS: | SCALE: | PART NO: 906M2-042A0 |
| | mm | NONE | SHEET: 1 OF 3 |

| | |
|-----|-----------|
| A | 08.4.2017 |
| REV | DATE |

RECOMMEND NGFF MINI CARD MOUNTING TYPE_SMT_PCB OUTLIN
 GENERAL TOLERANCE ±0.05mm

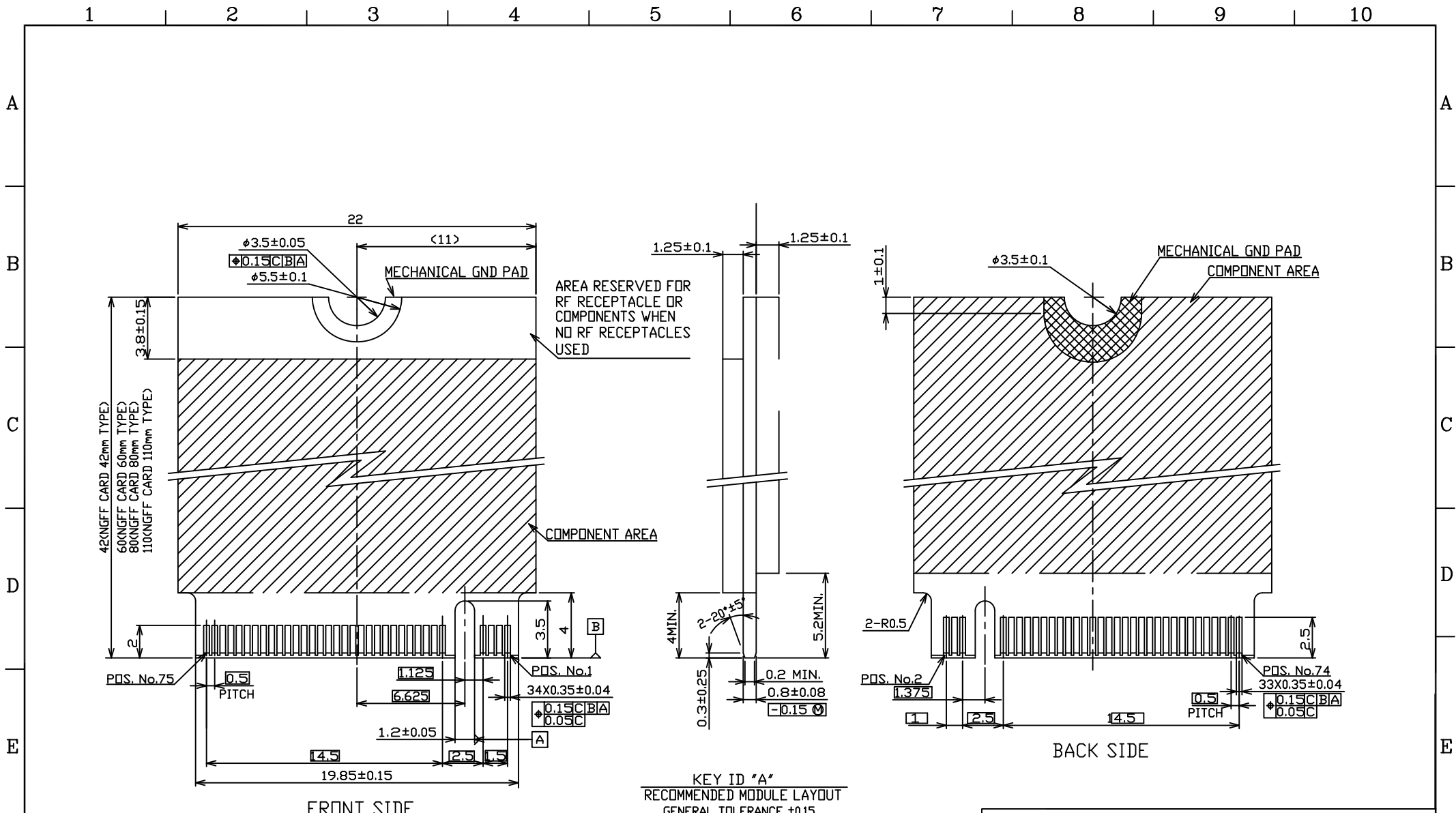

| | |
|-----|-----------|
| A | 08.4.2017 |
| REV | DATE |

| | | |
|---|----------------|--|
| PROPRIETARY NOTE: This document contains confidential information and proprietary to Rego Electronics and shall not be reproduced or disclosed to other documents or used for any purpose other than that for which was obtained without the expressed written consent of Rego Electronics. | | |
| .X ± 0.30 | APPROVED: |  http://www.rego.com.tw |
| .XX ± 0.20 | CHECKED: Chris | |
| .XXX ± 0.15 | DRAWN: Vic | TITLE: M.2 Connector 2.15H A Key Type |
| X° ± 3' | UNITS: mm | PART NO: 906M2-042A0 |
| | SCALE: NONE | SHEET: 2 OF 3 |

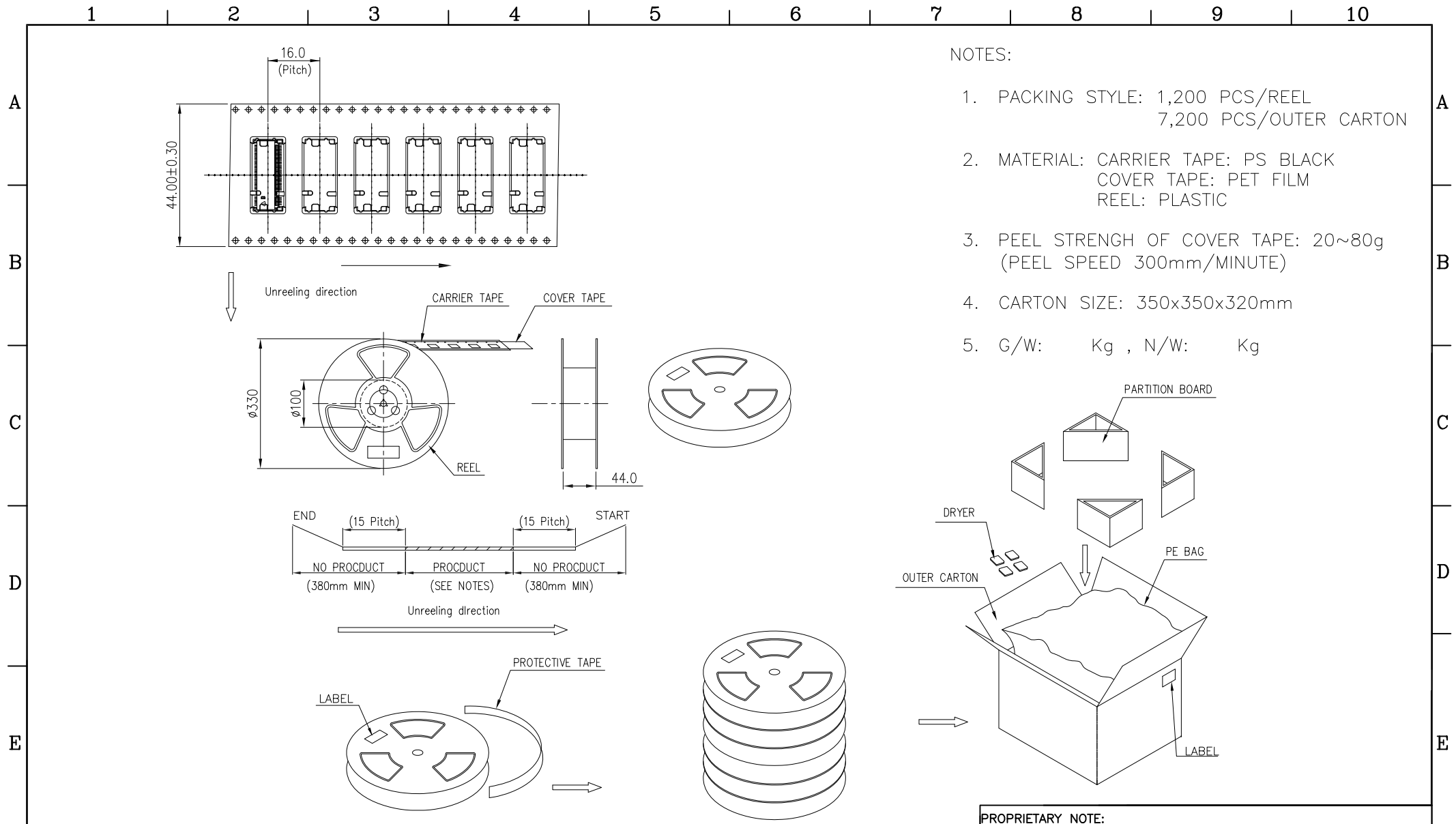

NOTES:

1. PACKING STYLE: 1,200 PCS/REEL
7,200 PCS/OUTER CARTON
2. MATERIAL: CARRIER TAPE: PS BLACK
COVER TAPE: PET FILM
REEL: PLASTIC
3. PEEL STRENGTH OF COVER TAPE: 20~80g
(PEEL SPEED 300mm/MINUTE)
4. CARTON SIZE: 350x350x320mm
5. G/W: Kg , N/W: Kg

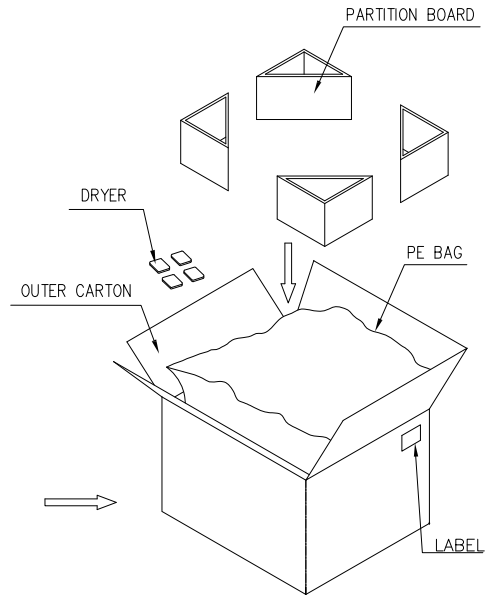

PROPRIETARY NOTE:

This document contains confidential information and proprietary to Rego Electronics and shall not be reproduced or disclosed to other documents or used for any purpose other than that for which was obtained without the expressed written consent of Rego Electronics.

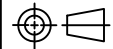
| | | |
|---|---------------------------------------|--|
| .X ± 0.30 | APPROVED: Chris |  http://www.rego.com.tw |
| .XX ± 0.20 | CHECKED: Andy | |
| .XXX ± 0.15 | DRAWN: Vic | |
| X* ± 3' | | |
|  | UNITS: mm | SCALE: NONE |
| | TITLE: M.2 Connector 2.15H A Key Type | |
| PART NO: 906M2-042A0 | | SHEET: 3 OF 3 |

| | |
|-----|-----------|
| A | 08.4.2017 |
| REV | DATE |